

Field Fabricate Expansion Joint
Transition Following Manufacturer's
Written Instructions

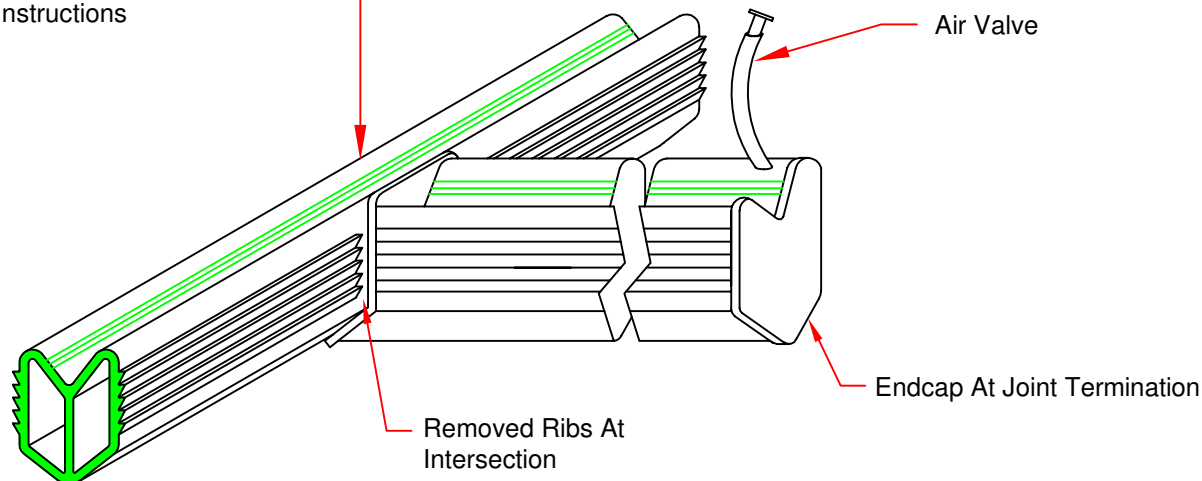

JOINT 3-WAY INTERSECTION ISOMETRIC

"T" SECTION SPLICE DETAIL
Jeene® "W" Profile Shown
Jeene® "FW" Profile Similar

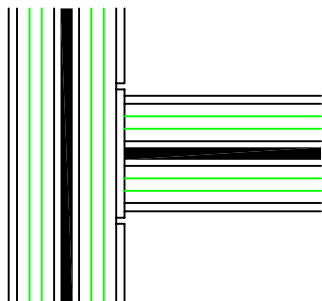

JOINT 3-WAY
INTERSECTION PLAN

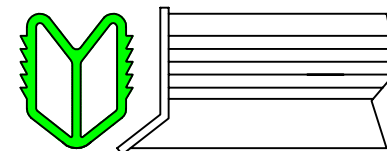

JOINT INTERSECTION
PRIOR TO ASSEMBLY

Wabo®Jeene

Model: FW & W



Watson Bowman Acme Corp.
95 Pineview Drive Amherst, NY 14228
phone: (716) 691-7566 fax: (716) 691-9239
www.wbacorp.com



Information provided herein, including but not limited to, any drawing, design, photograph, graphic, or statement(s) ("Materials") are proprietary and the property of Watson Bowman Acme Corporation ("Company"). Reproduction, translation, or reduction to any electronic medium or machine-readable form, in whole or part, is strictly prohibited, except for the express purpose for which it has been furnished, without prior written consent of Company. All Materials contained herein are provided by Company for information purposes only. Company reserves the right to amend or withdraw any information contained in the Materials without notice. All technical or other advice by Company, whether verbal or written, concerning products, or the use of products in specific situations ("Advice") is given by Company and is used at the Users own risk.

| | |
|---------------------|----------------------------|
| DETAILED BY: CTW | DATE: 12/14/06 |
| CHECKED BY: WBA | CURRENT ISSUE: 12/14/06 |
| SHEET NO: 8 | DRAWING NO: C - 96011 |